

PRODUCT SPECIFICATIONS

Holder for 4 backgrounds

227

Holder for 7 background is a component of Ventis Motorised Background Support System. It is used for background and motorised drives support.

Features

- Supports up to 4 backgrounds
- Max. load 100 kg
- Sturdy design
- Matt-black finish
- Control box mount option
- Modular design – can be combined with another 4 or 6 background holder

Basic Specifications

Dimensions max. (LxWxH)31x33x3cm (12x13x1,2")
Net weight (pair)4,2 kg (9,3 lbm)
Packaged dim. (LxWxH).....36x36x6cm (14,2x14,2x2,4")
Gross weight4,6 kg (10,1 lbm)
Max. load wall & ceiling fixed (*).....100 kg (220 lbm)
Max. load wall fixed (*).....70 kg (150 lbm)
(*) per holder pair

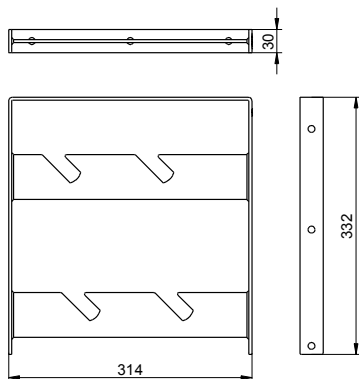

Related Background Lift System products:

220S 220S-110V – BLS 2.0 Control Box Pro
203S – Motorised drive
225 – Holder for 10 backgrounds
226 – Holder for 6 backgrounds
230US – US power supply cable
230EU – EU power supply cable